

## RV-4C REMOTE VFO

The RV-4C is designed for use with the TR-3, TR-4 and TR-4C transceivers. It permits reception, transmission, or both transmission and reception on a frequency removed from the VFO setting of the transceiver, but in the same band to which the transceiver is tuned. The RV-4C consists of a highly stable permeability-tuned solid-state VFO, a cathode follower, associated control circuitry and a 5-inch 4 Ohm speaker.

The unit is housed in a cabinet which matches the transceiver. An AC-4 (or AC-3) power supply can also be housed in this cabinet. The dimensions are as follows: 5-3/8 inches high, 10-3/4 inches wide and 11-1/8 inches deep. Weight is 6-1/2 lbs.

### INSTALLATION.

For use with the TR-4C it is necessary to plug the RV-4C into the RV-4 plug J2 on the bottom of the TR-4C chassis. No jumper need be removed when the unit is installed nor is a jumper plug needed when it is disconnected.

To operate the RV-4C with a TR-3, it is necessary to remove the bottom cover of the TR-3 and remove the jumper wire between pins 2 and 8 of the RV-3 jack (J2). Replace the bottom cover of the TR-3 and connect the RV-4C cable to J2. Connect the speaker lead to the 6-inch lead protruding from the power supply power cable connector.

When the RV-4C is disconnected from the TR-3, it is necessary to insert a jumper plug in the RV-3 jack. This plug should consist of an 8 conductor male plug (Cinch Jones Type P-308 with either the CCE, FHE, FHT, or CCT metal caps -remove cable clamps) with a jumper wire connected between pins 2 and 8.

#### NOTE

It is necessary to ground the RV-4C chassis to the transceiver chassis and to a good earth ground with a short piece of braid.

### OPERATION.

The RV-4C has two controls: The Main Tuning control and the RV-4C FUNCTION switch. The

Main Tuning control determines the frequency of the VFO and is calibrated in exactly the same way as the transceiver VFO. The RV-4C FUNCTION control has four positions: OFF, RCV, RCV/XMIT, and XMIT.

In the OFF position, the unit draws B+ and filament current but does not provide any output. The transceiver will transceive normally.

In the RCV position, the RV-4C determines the receiving frequency and the transceiver VFO determines the transmitting frequency.

In the RCV/XMIT position, both transmit and receive frequencies are determined by the RV-4C.

In the XMIT position, the RV-4C determines the transmitting frequency and transceiver VFO determines the receiving frequency.

The PTO indicator lamp is located to the right of the PTO dial. This lamp lights whenever the RV-4C is being used to control the frequency.

### SERVICE DATA.

We will check and align your RV-4C at the factory for a nominal fee if it has not been tampered with. Transportation charges are extra. Any necessary repairs will be made on a time and material basis. Please write or call the factory for authorization before returning your unit for alignment or service. Address your request for authorization to:

R. L. Drake Company  
540 Richard Street  
Miamisburg, Ohio 45342  
ATTN: Customer Service Department  
Telephone: (Area Code 513) 866-3211  
(Code-A-Phone Service after  
1630 Hours E.S.T.)

### REMOVAL FROM CABINET.

If the AC-4 (or AC-3) power supply is installed in the RV-4C cabinet, it will first be necessary to remove it from the cabinet by removing the four screws holding it to the bottom of the RV-4C cabinet and sliding it out the rear.

## TUBE REPLACEMENT.

In general, most trouble encountered in radio equipment of good design is due to tube failure. The RV-4C has been designed so that tube replacement can be made without need for realignment. The best method of finding defective tubes is direct substitution. It is best not to rely too heavily on tube checkers.

## TROUBLESHOOTING.

Careful consideration has been given in the design of the RV-4C to keep maintenance problems to a minimum. However, it is quite possible that some problem will arise which cannot be solved by tube substitution. If this occurs, we suggest that you either return your unit to your dealer or write direct to our service department describing your problem in detail. Include full information concerning external connections, control settings, tubes substituted etc. Do not return equipment to the factory without prior authorization.

The voltage and resistance charts and the schematic diagram should be valuable in isolating minor problems. However, no attempt should be made to service the RV-4C unless you are thoroughly familiar with electronic circuitry and servicing technique.

## ALIGNMENT.

The RV-4C is very carefully aligned at our factory and should require no further adjustment. If a tracking error in the VFO is noted, the unit should be returned to our factory. However, if the unit has the same calibration error from one end of the dial to the other, and if the error cannot be corrected by the movable index line, the dial scale can be slipped slightly on its shaft until the discrepancy is eliminated.

The only component in the RV-4C which should require any readjustment is coil L2. This coil is mounted inside the small aluminum can on the RV-4C chassis. To adjust L2 proceed as follows:

1. Switch the RV-4C FUNCTION switch to RCV and tune its VFO to the 4.0 MHz crystal calibrator signal. The transceiver FUNCTION switch should be on CAL and the BAND switch on 80.
2. Tune L2 for maximum S meter reading. Note that coil L3 has a value determined by the length of the cable connecting the RV-4C to the transceiver. Do not change the cable length or misalignment will result.

*Voltage Chart*

PIN	1	2	3	4	5	6	7	8	9
V1	170	0	42	12.6*	0	170	0	4.2	6.3*

NOTE: These measurements were made from ground with an 11 megohm VTVM. The RV-4C was connected to the transceiver which was in the receive condition. The RV-4C FUNCTION switch was on the RCV/XMIT position. An \* indicates AC voltage.

*Resistance Chart*

PIN	1	2	3	4	5	6	7	8	9
V1	11 K 8 K	33 K	180	0	0	11 K 8 K	33 K	180	0

NOTE: These measurements were made from ground with the RV-4C connected to the transceiver but with the transceiver disconnected from the power supply. Where two resistances are shown, the top value was obtained with the RV-4C connected to the TR-3 and the bottom value was obtained with the unit connected to the TR-4. The RV-4C FUNCTION switch was in the RCV/XMIT position.

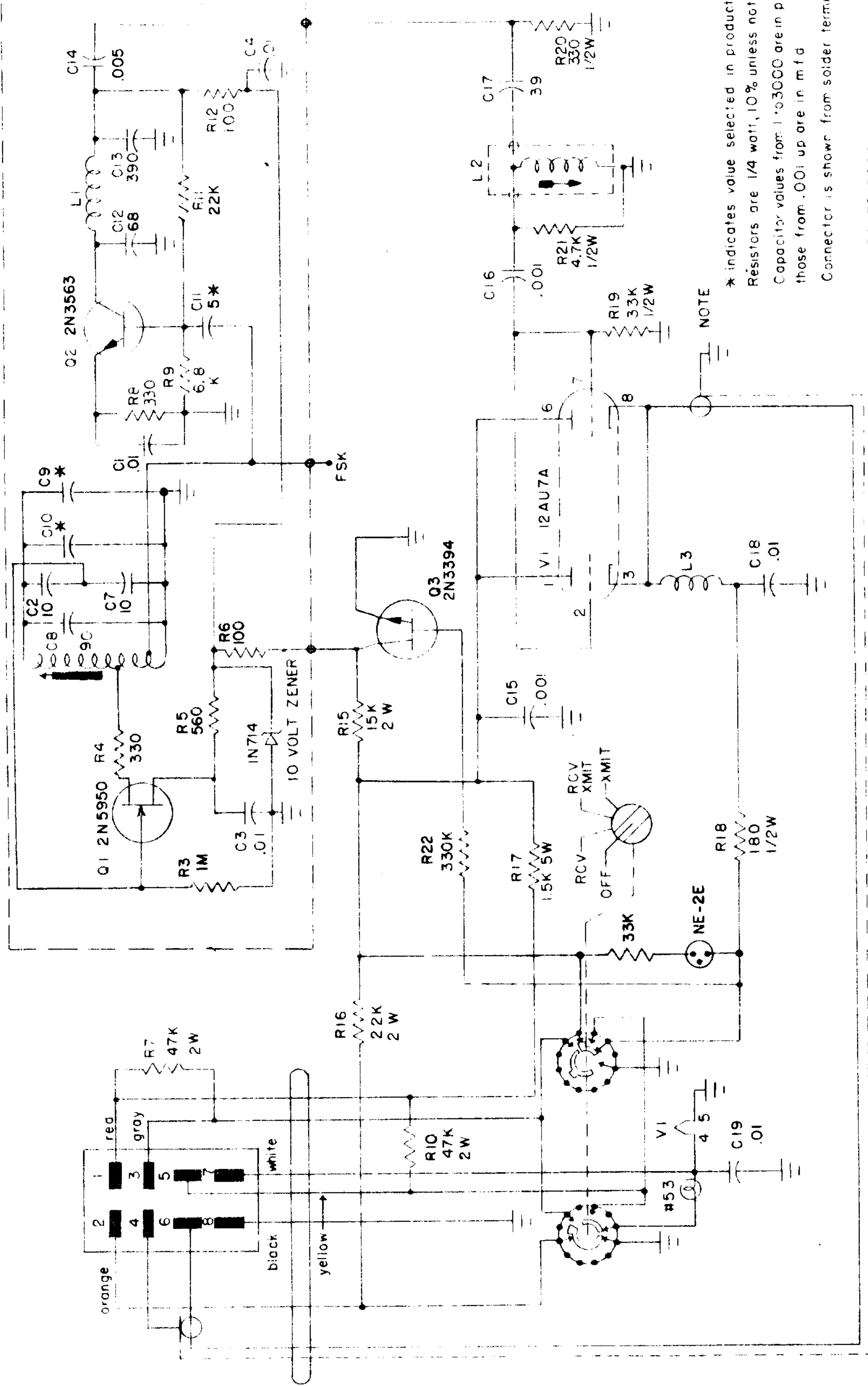

\* indicates value selected in production  
 Resistors are 1/4 watt, 10% unless noted  
 Capacitor values from 1 to 3000 are in pf and  
 those from .001 up are in mfd  
 Connector is shown from solder terminal end

SCHEMATIC DIAGRAM MODEL RV-4 C

2277318000

CABLE WIRE COLOR SUBSTITUTIONS  
 ORANGE IS NOW BLUE  
 GRAY IS NOW BROWN  
 YELLOW IS NOW GREEN